GARDNER DENVER®

15-515
3rd Edition
April, 1998

SINGLE ACTING TRIPLEX PUMP

9" STROKE

MODEL

PZJ99D

PARTS LIST

Gardner

Denver

MAINTAIN PUMP RELIABILITY AND PERFORMANCE WITH GENUINE GARDNER DENVER PARTS AND SUPPORT SERVICES

Gardner Denver® and OPI® genuine pump parts are manufactured to original tolerances and designed for optimum dependability. Design and material innovations are the result of years of experience with hundreds of different pump applications. Reliability in materials and quality assurance are incorporated in our genuine replacement parts.

Your authorized Gardner Denver and OPI distributor offers all the backup you'll need. A worldwide network of authorized distributors provides the finest product support in the pump industry.

Your local authorized distributor maintains a large inventory of genuine parts and he is backed up for emergency

parts by direct access to the Gardner Denver Machinery Inc. Master Distribution Center (MDC) in Memphis, Tennessee.

Your authorized distributor can support your Gardner Denver and OPI pump needs with these services:

1. Trained parts specialists to assist you in selecting the correct replacement parts.
2. Repair and maintenance kits designed with the necessary parts to simplify servicing your pump.

Authorized distributor service technicians are factory-trained and skilled in pump maintenance and repair. They are ready to respond and assist you by providing fast, expert maintenance and repair services.

For the location of your local authorized Gardner Denver and OPI distributor refer to the yellow pages of your phone directory or contact:

Distribution Center:
Gardner Denver Machinery Inc.
Master Distribution Center
5585 East Shelby Drive
Memphis, TN 38141
Phone: (901) 542-6100
Fax: (901) 542-6159

Factory:
Gardner Denver Machinery Inc.
1800 Gardner Expressway
Quincy, IL 62301
Phone: (217) 222-5400
Fax: (217) 224-7814

INSTRUCTIONS FOR ORDERING REPAIR PARTS

When ordering parts, specify Pump MODEL and SERIAL NUMBER (see nameplate on unit). The Serial Number is also stamped on top of the cylinder end of the frame (cradle area).

All orders for Parts should be placed with the nearest authorized distributor.

Where NOT specified, quantity of parts required per pump or unit is one (1); where more than one is required

per unit, quantity is indicated in parenthesis. **SPECIFY EXACTLY THE NUMBER OF PARTS REQUIRED.**

DO NOT ORDER BY SETS OR GROUPS.

To determine the Right Hand and Left Hand side of a pump, stand at the power end and look toward the fluid end. Right Hand and Left Hand are indicated in parenthesis following the part name, i.e. (RH) & (LH), when appropriate.

TABLE OF CONTENTS

	Page
Maintain Pump Reliability And Performance With Genuine Gardner Denver Parts And Support Services	1
Instructions For Ordering Repair Parts	1
Frame & Miscellaneous Parts	3, 4
Drive Parts	5, 6
Fluid Cylinder & Manifolds	7, 8
Steel-Fitted Center Guided Valve	9
With Polyurethane Insert	9
With Carboxylated Nitrile Insert	9
Plunger Coupling & Piston Rod	10
Piston & Liner	10
Piston Lubricating Pump	11
Oil Pump	12
Oil Pump & Piping	13, 14
Piston Lubricating Piping	15, 16
Oil Filter	17
Valve Seat Puller Center Guided Type (Optional Equipment)	18
Optional Equipment	19
Gardner Denver Unit Record	Inside Back Cover

For Operating and Service Instructions see:

SERVICE MANUAL 15-600

FRAME & MISCELLANEOUS PARTS

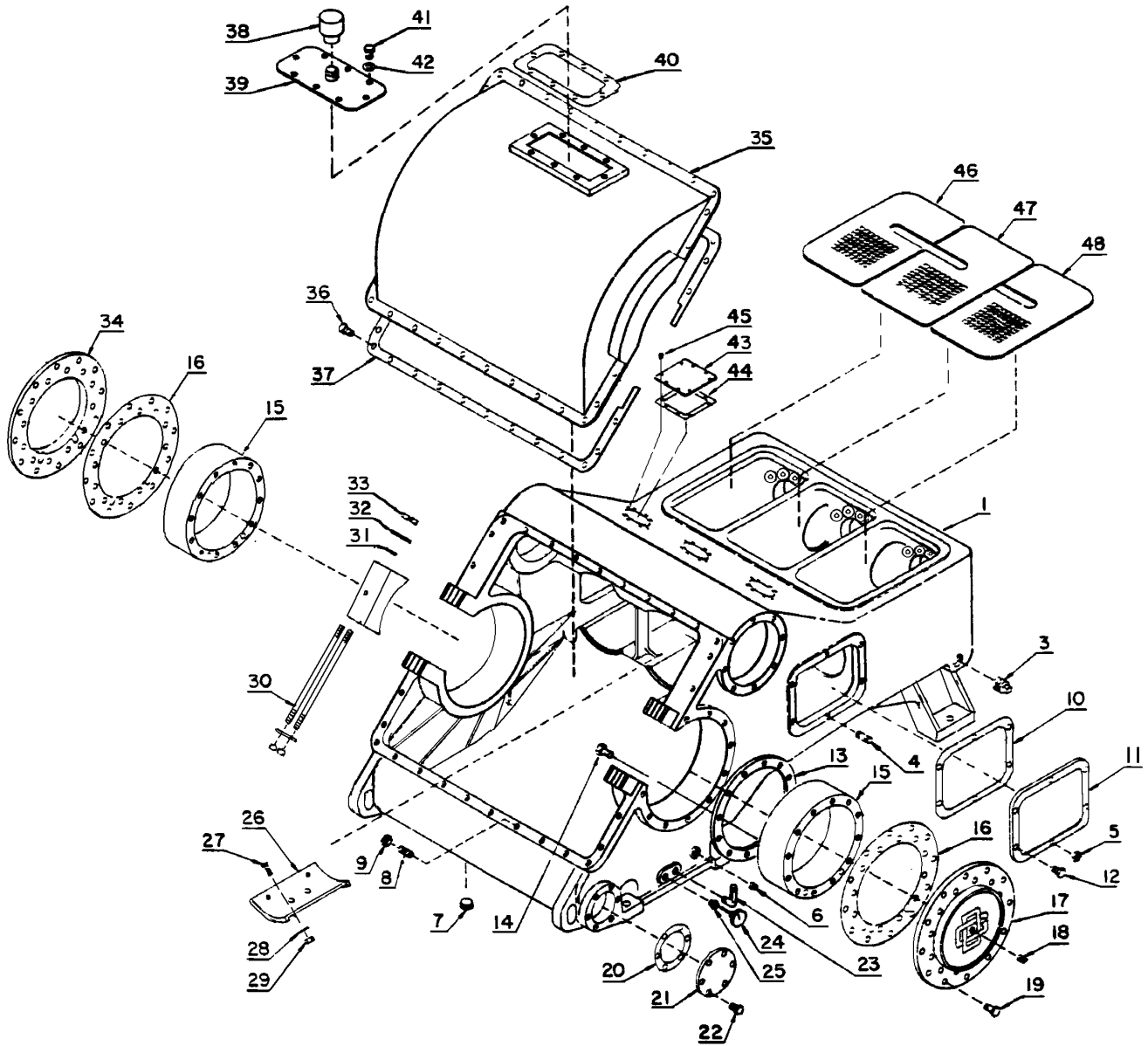

207PZL797
(Ref. Drawing)

FOR LIST OF PARTS SEE PAGE 4

FRAME & MISCELLANEOUS PARTS

Ref. No.	Name of Part	Qty.	Part No.
1	FRAME ASSEMBLY, Includes Reference Numbers 2 thru 9	1	PZ172A
2	PLUG-SqHd PIPE	2	64A27
3	PLUG-SqHd PIPE	1	64AA9
4	STUD, Crosshead Inspection Plate	2	79A238
5	NUT, Crosshead Inspection Stud	2	50B5
6	PLUG-SqHd PIPE	1	64A5
7	PLUG-MAGNETIC, Oil Drain	3	66D13
8	STUD, Hood	2	79A75
9	NUT, Hood Stud	2	50B7
10	GASKET, Crosshead Inspection Plate	2	PZ715
11	PLATE-INSPECTION, Crosshead	2	1PZ723
12	SCREW, Crosshead Inspection Plate	10	655EE060
13	PLATE-BEARING RETAINER	1	200PZJ253
14	SCREW, Bearing Retainer Plate	12	655EG050
15	HOUSING-BEARING, Eccentric	2	PZ1280
16	GASKET, Bearing Cover Plate	2	1PZ715N
17	PLATE-BEARING COVER (Rigid Side)	1	PZ196
19	SCREW, Bearing Cover Plate	48	655EG070
20	GASKET, Inspection Plate	1	25C1788N
21	PLATE-INSPECTION	1	202FXT052
22	SCREW, Inspection Plate	6	655EF050
23	GAUGE, Oil Level Sight	1	40L17
24	GAUGE-TEMPERATURE	1	27H11
25	BUSHING-PIPE	1	64E2
26	SLIDE-CROSSHEAD	6	PZ222
27	SCREW, Crosshead Slide to Frame	24	75K72
28	SEAL-FASTENER	12	60DD35
29	LOCKNUT	24	50V41
30	STUD, Spacer to Frame	4	PZ872
31	KEY, Spacer to Frame	4	35C24
32	PLATE	4	PZ1128
33	NUT, Spacer to Frame	8	50B37
34	PLATE-BEARING COVER (Floating Side)	1	1PZ196
35	HOOD	1	PZ246
36	SCREW, Hood to Frame	30	655EF050
37	GASKET, Hood	1	2PZ715
38	BREATHER	1	5C24
39	PLATE-INSPECTION	1	KXG842
40	GASKET, Inspection Plate	1	25C1818
41	SCREW, Inspection Plate	8	655EF040
42	GASKET, Inspection Plate Screw	8	25F13
43	PLATE-INSPECTION	3	206PZL052
44	GASKET, Inspection Plate	6	25C1839
45	SCREW, Inspection Plate	24	655ED040
46	PLATE-INSPECTION, Piston Rod	1	2006929
47	PLATE-INSPECTION, Piston Rod	1	PZ842
48	PLATE-INSPECTION, Piston Rod	1	1PZ842
*	PLUG-CSK PIPE	2	64AA7
*	SHIM-Frame to Skid Mounting	4	77E27
*	SHIM-Frame to Skid Mounting	4	77E28

* Not Shown on Drawing

DRIVE PARTS

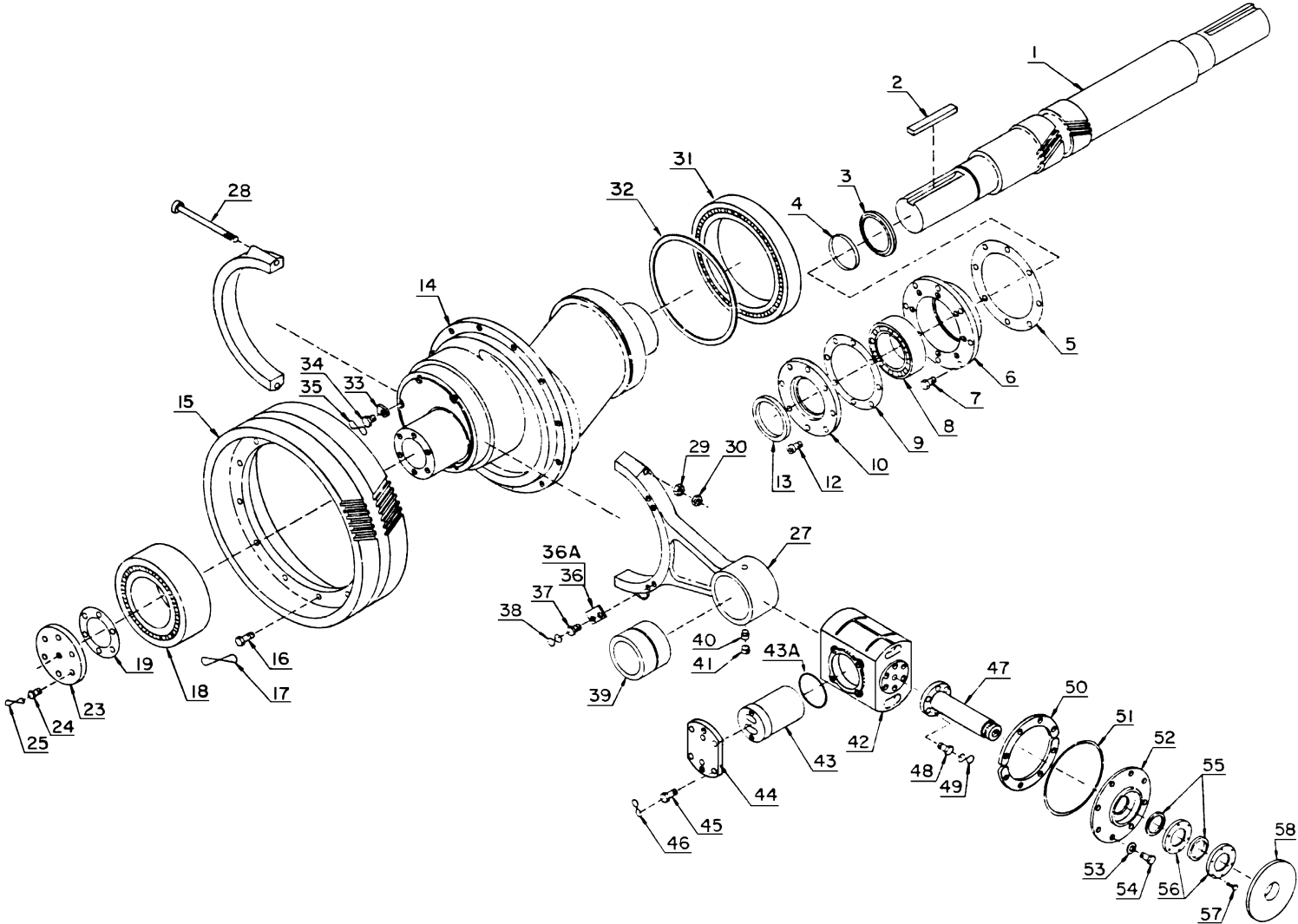

15-515 Page 5

200PZJ797
Ref. Drawing

FOR LIST OF PARTS SEE PAGE 6

Order by Part Number and Description. Reference Numbers are for your convenience only.

DRIVE PARTS

Ref. No.	Name of Part	Qty.	Part No.	Ref. No.	Name of Part	Qty.	Part No.
1	JACKSHAFT	1	1PZ371	34	SCREW, Bearing to Eccentric	14	655EF05D
2	KEY-JACKSHAFT	1	35B380	35	WIRE	384"	97A29
3	SPACER, Jackshaft Bearing	2	PZ649	36	PLATE-RETAINING, Bearing to Connecting Rod .	22	PZ1400
4	SLEEVE-WEAR	2	80L3	36A	PLATE-RETAINING, Bearing to Connecting Rod .	2	203PZL253
5	GASKET, Bearing Housing to Frame	2	25C2377	37	SCREW, Bearing to Connecting Rod	48	75B41
6	HOUSING-BEARING	2	PZ368	38	WIRE	288"	97A29
7	SCREW, Bearing to Frame	16	75A52	39	BEARING-ROLLER, Crosshead Pin	3	12AM3
8	BEARING-ROLLER, Jackshaft	2	12W60	40	PIN-LOCK	3	PZ838
9	GASKET, Retainer Plate to Bearing Housing		25C2692	41	SET SCREW	3	76F10
10	PLATE, Bearing Retainer	2	PZ370	42	CROSSHEAD	3	200PZJ005
12	SCREW, Retainer Plate to Bearing Housing	16	655EF060	43	PIN-CROSSHEAD	3	PZ189
13	SEAL-OIL	2	60G242	43A	RING-RETAINING, Bearing	3	16AUX203
14	ECCENTRIC	1	2013705	44	PLATE-RETAINER, Crosshead Pin	3	201PZJ168
15	GEAR-DRIVEN	1	1PZ180	45	SCREW, Crosshead Pin Retainer	18	75AG17
16	SCREW, Gear to Eccentric	12	75B150	46	WIRE	72"	97A29
17	WIRE	144"	97A29	47	ROD-EXTENSION	3	PZ183
18	BEARING-ROLLER, Eccentric	2	12GF36	48	SCREW, Rod to Crosshead	18	PV701
19	SHIM (.062")	2	77C55	49	WIRE	72"	97A29
23	PLATE-RETAINER, Eccentric Bearing	2	PZ1206	50	PLATE-RETAINER, Oil Stop Head to Frame	6	200PZJ168
24	SCREW, Retainer to Eccentric	12	75B28	51	GASKET, Oil Stop Head	3	25C2693
25	WIRE	48"	97A29	52	HEAD-OIL STOP	3	1PZ226
27	CONNECTING ROD, Includes Ref. Nos. 28 & 29 .	3	PZ417	53	GASKET	24	25F9
28	BOLT-CONNECTING ROD	6	PZ890	54	SCREW, Oil Stop Head to Frame	24	655EE080
29	NUT, Connecting Rod Bolt	6	50B34	55	SEAL, Oil Stop Head	6	2011872
30	LOCKNUT, Connecting Rod Bolt	6	50M3	56	RING-RETAINER, Oil Stop Head Seal	6	1PV1398
31	BEARING, Connecting Rod to Eccentric	3	12W84	57	SCREW, Seal Retainer to Oil Stop Head	18	75A102
32	RING-RETAINING, Connecting Rod Bearing	1	2009808	58	BAFFLE-ROD	3	PZ840
33	PLATE-RETAINING, Bearing to Eccentric	14	1PZ1400	*	ADAPTOR, For Rotating Shaft	1	2PO1398
				*	SCREW, Adaptor to Shaft	2	655EF050

* Not Shown on Drawing.

FLUID CYLINDER & MANIFOLDS

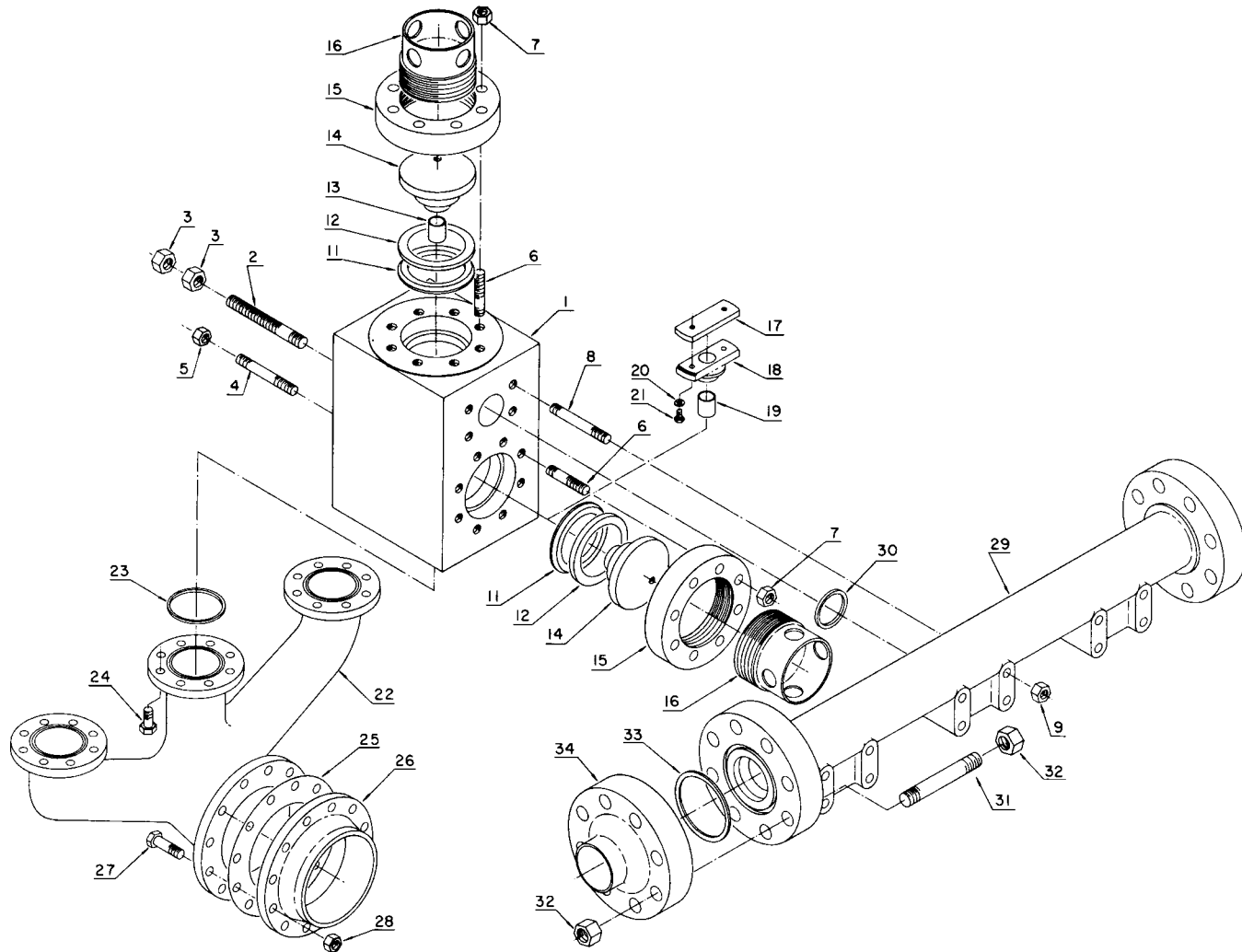

E75439

FOR LIST OF PARTS SEE PAGE 8

Order by Part Number and Description. Reference Numbers are for your convenience only.

FLUID CYLINDER & MANIFOLDS

Ref. No.	Name of Part	Qty.	Part No.
1	FLUID CYLINDER ASSEMBLY, Includes Reference Numbers 2 thru 9	3	205PZL029D
2	STUD, Cylinder to Frame & Liner Clamp	24	79L188
3	NUT, Cylinder to Frame & Liner Stud	48	50B36
4	STUD, Cylinder to Frame	12	79L73
5	NUT, Cylinder to Frame Stud	12	50AQ30
6	STUD, Valve Cover to Cylinder	48	79AL6
7	NUT, Valve Cover Ring to Cylinder Stud	48	50B34
8	STUD, Cylinder to Discharge Manifold	12	202PZL110
9	NUT, Cylinder to Discharge Manifold Stud	12	50B34
11	RING-RETAINING, Valve Cover Gasket	6	2011861
12	GASKET, Valve Cover	6	2011862
13	BUSHING, Suction & Discharge Valve Cover	6	2007674
14	COVER-VALVE	6	2011860
15	RING-VALVE COVER	6	2011699
16	LOCK-COVER, Valve	6	2011857
	VALVE GUIDE ASSEMBLY, Includes Reference Numbers 17 thru 21	3	2011706
17	PLATE-RETAINER	3	2011701
18	GUIDE-VALVE, Suction	3	2011700
19	BUSHING, Suction Valve Guide	3	2007674
20	LOCKWASHER	6	95W2
21	SCREW	6	655EE06S
22	MANIFOLD-SUCTION	1	200PZJ069
23	GASKET, Suction Manifold to Cylinder	3	25G41
24	SCREW, Suction Manifold to Cylinder	24	655EG08N
25	GASKET, Suction Manifold Flange	1	25C1154N
26	FLANGE, Suction	1	64CU12
27	SCREW, Suction Flange	12	75A150
28	NUT	12	50B9
29	MANIFOLD-DISCHARGE	1	200PZJ071
30	GASKET, Discharge Manifold to Cylinder	3	25AL35
31	STUD, Discharge Manifold Flange	16	209PZL110
32	NUT, Discharge Manifold Flange Stud	32	50AW11
33	GASKET-RING JOINT, Discharge Manifold Flange	2	25V24
34	FLANGE-DISCHARGE	1	64EB15
*	FLANGE-BLIND	1	64EB240

* Not Shown on Drawing

Order by Part Number and Description. Reference Numbers are for your convenience only.

STEEL-FITTED CENTER GUIDED VALVE

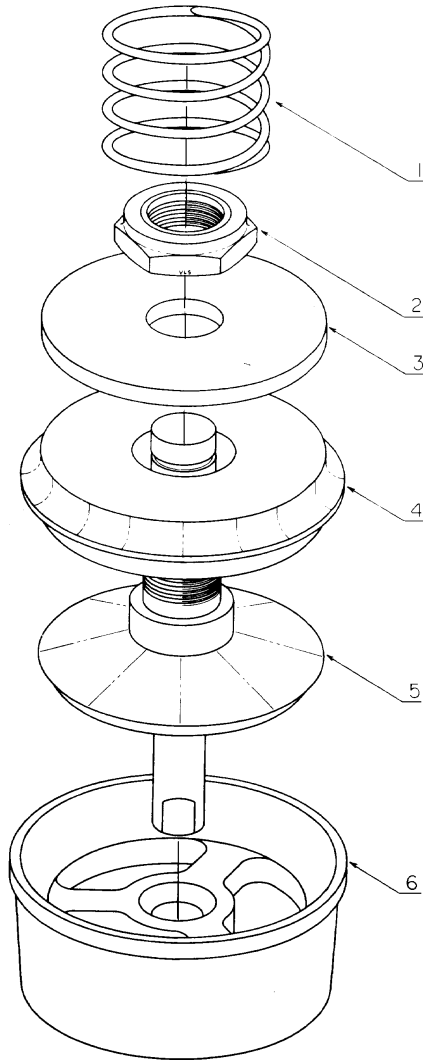

C76502

Ref. No.	Name of Part	Qty.	Part No.
WITH POLYURETHANE INSERT			
	FLUID VALVE ASSEMBLY, Includes Ref. Nos. 2 thru 5 .	6	202PZL482A
1	SPRING	6	78H44
2	LOCKNUT	6	50V27
3	WASHER-VALVE	6	201PZL279
4	INSERT (Polyurethane)	6	201PZL106
5	VALVE-FLUID	6	202PZL482
6	SEAT-VALVE*	6	202PZL039

* For Valve Seat Puller, see Page 18.

Ref. No.	Name of Part	Qty.	Part No.
WITH CARBOXYLATED NITRILE INSERT			
	FLUID VALVE ASSEMBLY, Includes Ref. Nos. 2 thru 5 .	6	202PZL482B
1	SPRING	6	78H44
2	LOCKNUT	6	50V27
3	WASHER-VALVE	6	201PZL279
4	INSERT (Carboxylated)	6	202PZL106
5	VALVE-FLUID	6	202PZL482
6	SEAT-VALVE*	6	202PZL039

* For Valve Seat Puller, see Page 18.

Order by Part Number and Description. Reference Numbers are for your convenience only.

PLUNGER COUPLING & PISTON ROD

Ref. No.	Name of Part	Qty.	Part No.
PLUNGER COUPLING ASSEMBLY			
	Includes Reference Numbers 1, 2 & 3	3	200PZJ4065
1	COUPLING-PLUNGER	6	200PZJ092
2	SCREW, Coupling Plunger	6	655EE22S
3 *	NUT, Flanged	6	50AW35
4	PISTON ROD, Includes Reference No. 5 . .	3	1PZ183
5	LOCKNUT	3	50V14
6	CLAMP-LINER	3	1PV14
7	GASKET, Liner to Cylinder	3	25AT37
*	WRENCH	1	99L11

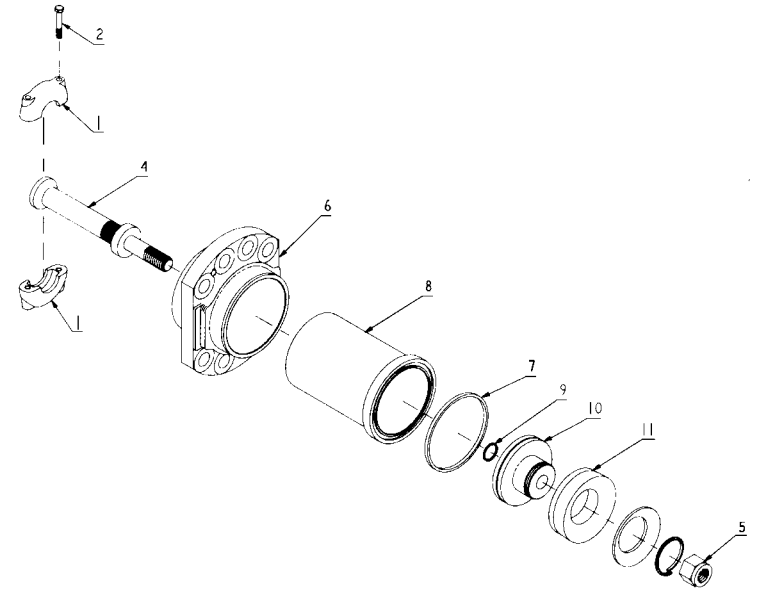

C77013

* Not shown on drawing

PISTON & LINER

Ref. No.	Name of Part	Qty.	7" Part No.	6-1/2" Part No.	6-1/4" Part No.	6" Part No.	5-1/2" Part No.	5" Part No.	4-1/2" Part No.	4" Part No.
8	LINER	3	207PZJ456	200PZJ456	201PZJ456	202PZJ456	203PZJ456	204PZJ456	205PZJ456	206PZJ456
9	O-RING	3	25AH1	25AH1	25AH1	25AH1	25AH1	25AH1	25AH1	25AH1
10	PISTON ASSEMBLY, Incl. Ref. Nos. 9 & 11	3	202TBL045A	201TBL045A	200TBL045A	245TBB045A	243TBB045A	241TBB045A	239TBB045A	231TBK045A
11	INSERT GROUP, Incl. Retainer Plates and Rings	3	TBL77586	TBL77585	TBL77584	TBB76028	TBB76026	TBB76024	TBB76022	TBK90428

Order by Part Number and Description. Reference Numbers are for your convenience only.

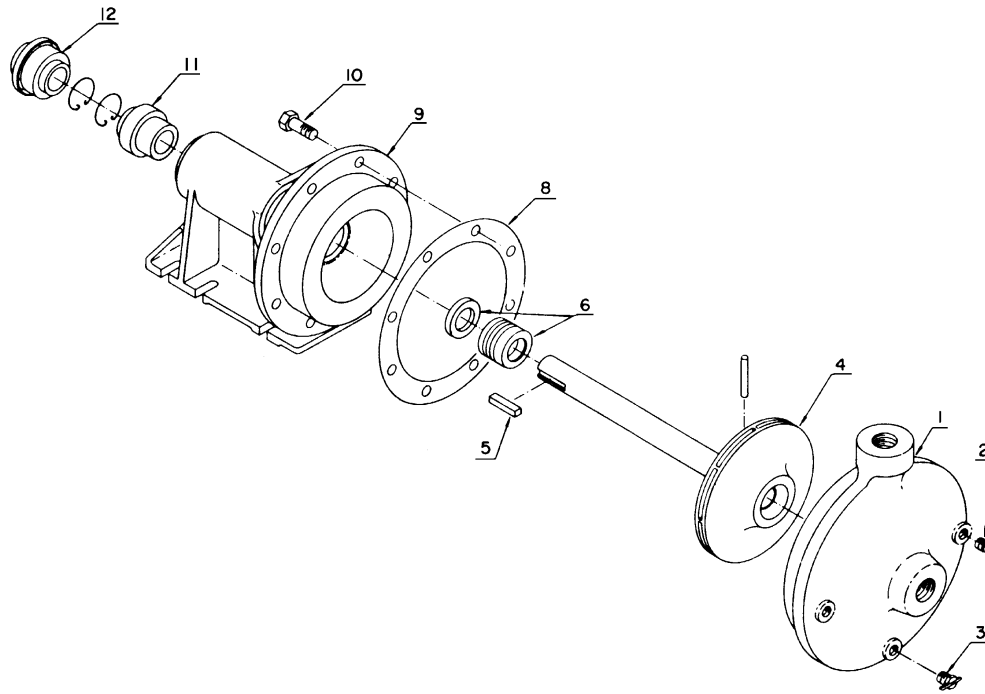

PISTON LUBRICATING PUMP

Ref. No.	Name of Part	Qty.	Part No.
	PUMP ASSEMBLY, Includes All Parts Shown		CA122
1	CASING	1	C1K2A1
2	PLUG-SqHd PIPE	2	64AA6
3	COCK, Drain	1	90C31
4	IMPELLER ASSEMBLY, SHAFT & PIN	1	C1K1A1A
5	KEY	1	35B4
6	SEAL	1	60BT11
8	GASKET	1	25D212
9	FRAME	1	C1H4A2
10	SCREW	8	75A130
11	BEARING-BALL (Inner) Includes Retaining Ring	1	12AK3
12	BEARING-BALL (Outer) Includes Retaining Ring	1	12AK3

Order by Part Number and Description. Reference Numbers are for your convenience only.

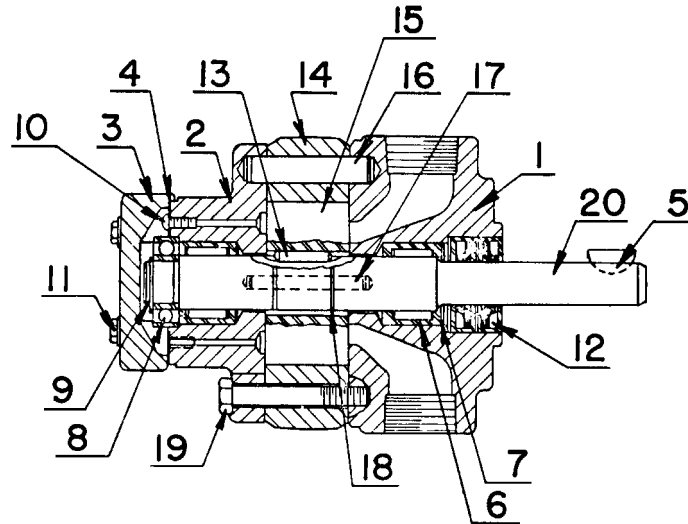

B73228

OIL PUMP

Ref. No.	Name of Part	Qty.	Part No.
	PUMP, Includes All the Following Items	1	46C21
1	BODY	1	_____
2	HEAD	1	_____
3	CAP, End	1	_____
4	GASKET	1	2010024
5	KEY, Drive	1	_____
6	BEARING, Shaft	2	2010025
7	RING, Snap	1	_____
8	BEARING, Thrust	1	2010026
9	RING, Snap	1	_____
10	SCREW, Drain Plug	1	_____
11	SCREW, Hex Head	4	_____
12	SEAL	1	2010027
13	KEY, Rotor	1	_____
14	RING, Eccentric	1	_____
15	ROTOR SET	1	2010208
16	PIN, Eccentric	2	_____
17	PIN, Locating	1	_____
18	RETAINER, Key	2	_____
19	SCREW, Hex Head	8	_____
20	SHAFT	1	_____

Note: Part Numbers listed only for those parts normally furnished for repairs.

OIL PUMP & PIPING

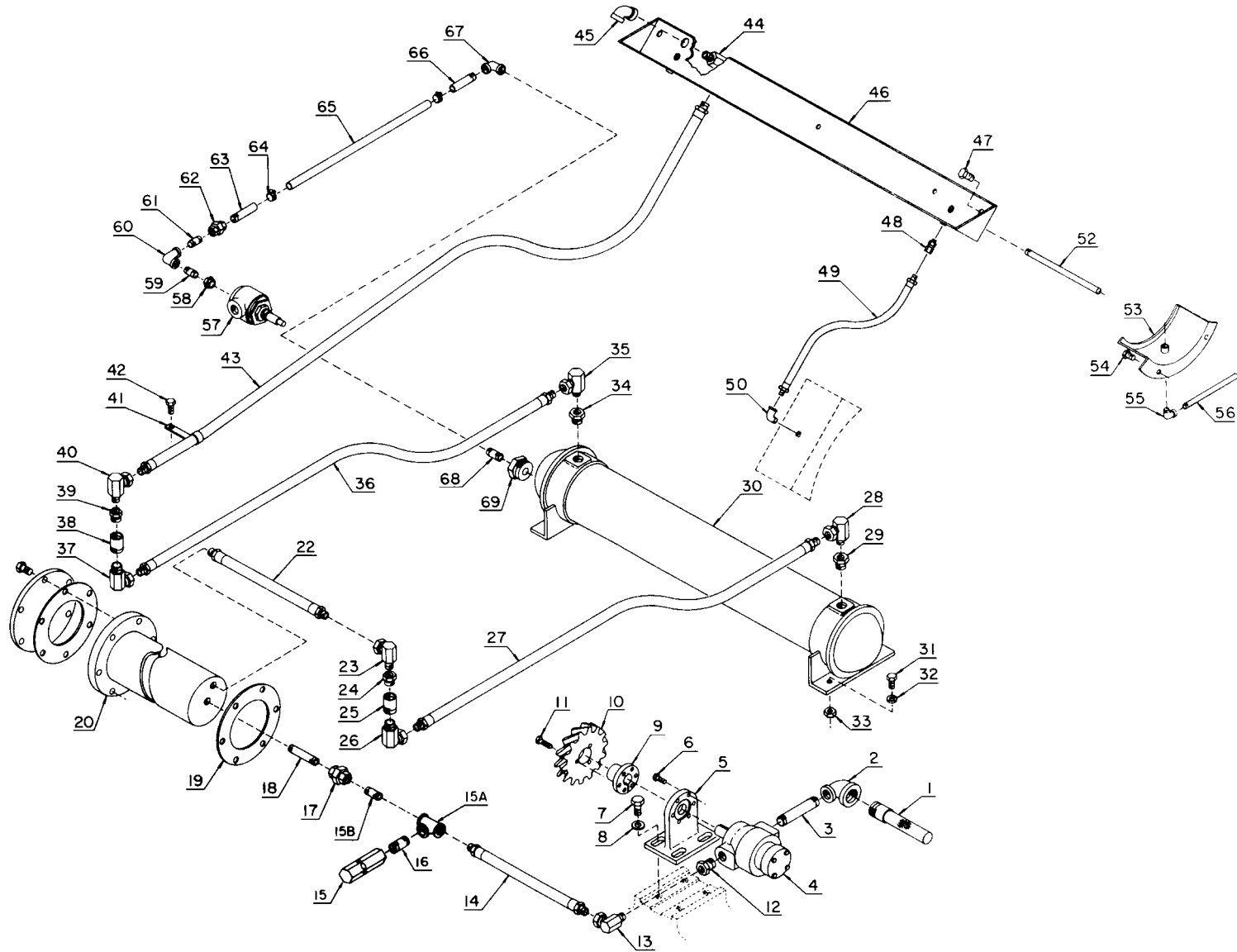

Order by Part Number and Description. Reference Numbers are for your convenience only.

OIL PUMP & PIPING

Ref. No.	Name of Part	Qty.	Part No.	Ref. No.	Name of Part	Qty.	Part No.
1	SCREEN-OIL	1	3WAJ511	34	BUSHING-PIPE	1	64E11
2	ELBOW	1	64S12	35	ADAPTOR-HOSE	1	29Q10
3	NIPPLE	1	63H4	36	HYDRAULIC HOSE ASSEMBLY	1	29Z2
4	PUMP-OIL *	1	46C21	37	ADAPTOR-HOSE	1	29Q10
5	ADAPTOR, Oil Pump to Frame	1	PZ1398	38	CONNECTOR, Frame	1	78AUX113
6	SCREW, Adaptor to Oil Pump	6	655ED04D	39	BUSHING-PIPE	1	64E16
7	SCREW, Adaptor to Frame	4	655EF05D	40	ADAPTOR-HOSE	1	29Q17
8	WASHER	4	95U7	41	CLAMP, Hose to Frame	1	PZ1301
9	BUSHING-HUB, Gear, Includes Reference Nos. 11	1	22F12SD	42	SCREW, Hose to Frame Clamp	1	655EF040
10	GEAR-DRIVEN, Oil Pump	1	2013884	43	HYDRAULIC HOSE ASSEMBLY	1	29Z5
11	SCREW, Gear to Bushing (Included with Ref. No. 9)	6		44	ADAPTOR-HOSE	1	29Q16
∅	WIRE, Adaptor to Oil Pump	12"	97A29	45	ELBOW	1	64C5
∅	WIRE, Adaptor to Frame Screw	24"	97A29	46	TROUGH, Oil Feed	1	2PZ1254
				47	SCREW, Oil Feed Trough to Frame	2	655EF040
	(Oil Pump to Filter Group)				(Oil Trough to Main Bearings Group)		
12	BUSHING-PIPE	1	64E16	48	ADAPTOR-HOSE	2	29Q54
13	ADAPTOR-HOSE	1	29Q17	49	HYDRAULIC HOSE ASSEMBLY	2	29Z99
14	HYDRAULIC HOSE ASSEMBLY	1	29N1	50	ELBOW-PIPE	2	64D4
15	VALVE-LIQUID RELIEF	1	90AR28	52	NIPPLE, Oil Feed Trough to		
16	NIPPLE	1	63U12X16		Jackshaft Oil Trough	2	63AJ6X144
17	TEE	1	64G7	53	TROUGH, Jackshaft Bearing Oil	2	PZ1254
19	NIPPLE	1	63U12X34	54	SCREW, Jackshaft Oil Trough	6	655EF04D
20	FILTER-OIL **	1	26C18	∅	CLAMP, Hose to Main Bearing Housing	1	PZ1301
∅	NIPPLE	1	63U12X50	∅	SCREW, Clamp	1	655EG04N
∅	UNION-STRAIGHT	1	64Z8	∅	WASHER, Clamp Screw	1	95A8
				∅	WIRE, Trough Screw	96"	97A29
	(Filter to Heat Exchanger Group) ***				(Thermostat Valve to Heat Exchanger Group) ***		
22	HYDRAULIC HOSE ASSEMBLY	1	29N1	57	VALVE-THERMOSTAT	1	90K165
23	ADAPTOR-HOSE	1	29Q17	58	BUSHING-PIPE	1	64E14
24	BUSHING-PIPE	1	64E16	59	NIPPLE	1	63F21
25	CONNECTOR, Frame	1	78AUX113	60	ELBOW	1	64C4
26	ADAPTOR-HOSE	1	29Q10	61	NIPPLE	1	63F21
27	HYDRAULIC HOSE ASSEMBLY	1	2009270	62	UNION	1	64Z3
28	ADAPTOR-HOSE	1	29Q10	63	NIPPLE	1	63AJ8X40
29	BUSHING-PIPE	1	64E11	64	CLAMP-HOSE	2	29B31
30	HEAT EXCHANGER	1	2013457	65	HOSE-OIL	22"	R14G
31	SCREW, Heat Exchanger to Skid	4	655EE060	66	NIPPLE	1	63AJX840
32	LOCKWASHER	4	95B5	67	ELBOW	1	64C4
33	NUT	4	50B5	68	NIPPLE	1	63F21
∅	PLUG-ZINC, Heat Exchanger Protector	1	2008076	69	BUSHING	1	64E29

∅ Not Shown on Drawing.

* For Oil Pump and Component Parts See Page 12.

** For Oil Filter and Component Parts See Page 17.

*** Reference Numbers 22 thru 39, and 57 thru 69 are available as Optional Equipment.

PISTON LUBRICATING PIPING

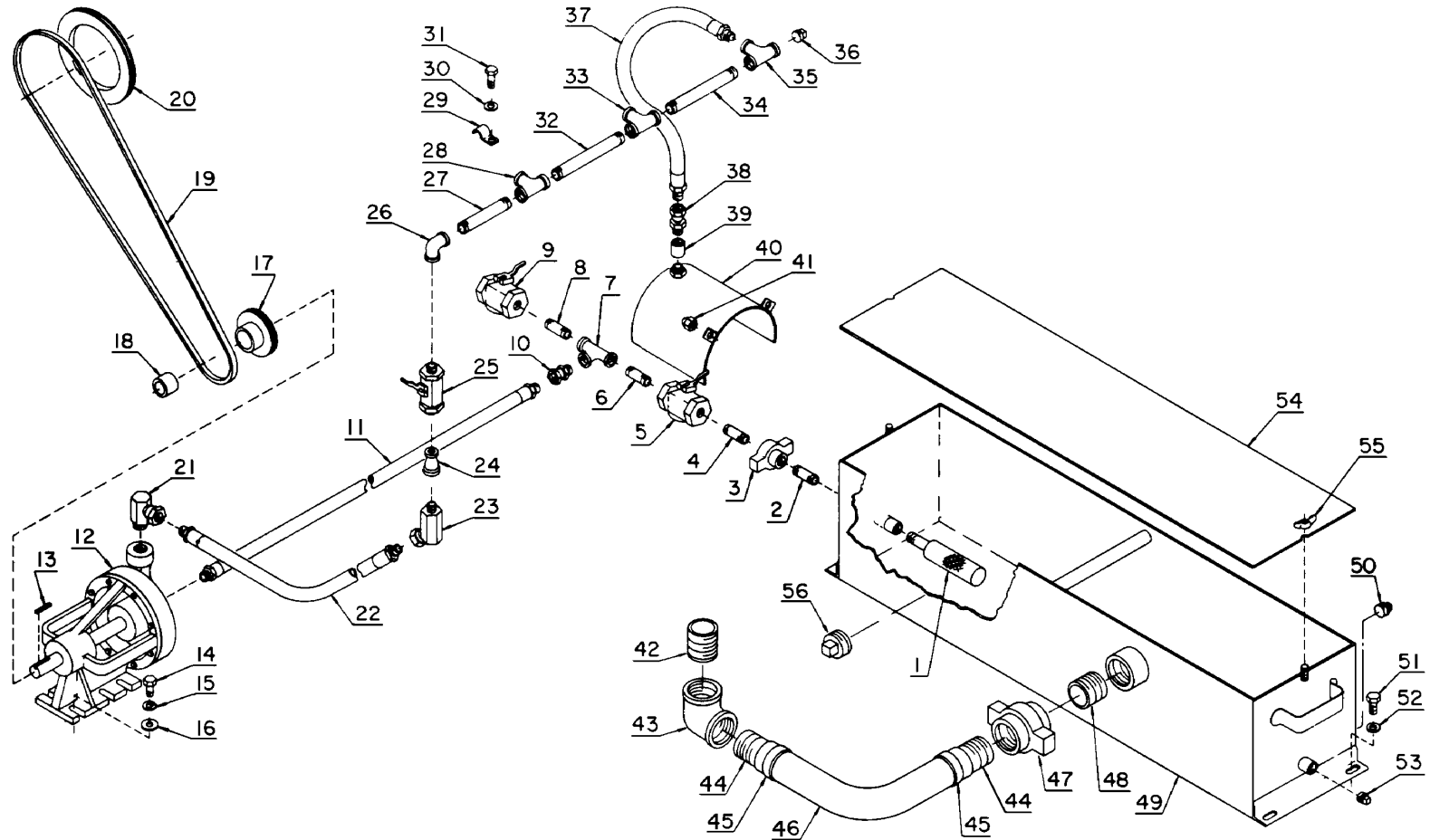

Order by Part Number and Description. Reference Numbers are for your convenience only.

PISTON LUBRICATING PIPING

Ref. No.	Name of Part	Qty.	Part No.	Ref. No.	Name of Part	Qty.	Part No.
	(Lube Oil Tank to Pump Group)			27	NIPPLE	1	63G12
1	SCREEN-OIL	1	2WAJ511	28	TEE	1	64P39
2	NIPPLE	1	63H25	29	CLAMP	2	98H5
3	UNION-HAMMER, Wing	1	64EB1	30	WASHER	2	95B3
4	NIPPLE	1	63H25	31	SCREW	2	75A68
5	VALVE	1	90A36	32	NIPPLE	1	63N12X144
6	NIPPLE	1	63H25	33	TEE	1	64P39
7	TEE	1	64G8G	34	NIPPLE	1	63N12X144
8	NIPPLE	1	63H25	35	TEE	1	64P39
9	VALVE	1	90A36	36	PLUG	1	64A5
10	ADAPTOR-HOSE	1	29Q9	37	HYDRAULIC HOSE ASSEMBLY	3	29R32
11	HYDRAULIC HOSE ASSEMBLY	1	2009270	38	ADAPTOR-HOSE	3	29Q83
∅	NIPPLE	1	63H2	39	COUPLING-PIPE	3	64BK3
∅	ELBOW	1	64C6	40	BAFFLE	3	200PZJ840
				41	NUT-ACORN	6	50Q30
12	PUMP PISTON LUBRICATING, *				(Frame to Lube Oil Tank Group)		
	Includes Reference Number 13	1	CA122	42	NIPPLE	1	63L9
13	KEY	1	35B4	43	ELBOW	1	64C9
14	SCREW, Pump to Skid	4	655ED040	44	NIPPLE	2	63AJ32X134
15	LOCKWASHER, Pump to Skid	4	95B3	45	CLAMP	2	29B32
16	WASHER, Pump to Skid	4	95A3	46	HOSE	1	29Z186
17	SHEAVE	1	73K1A30	47	UNION-HAMMER, Wing	1	2009242
18	BUSHING-HUB	1	22E16B	48	NIPPLE	1	63L9
19	BELT	1	13C77	49	TANK-LUBE OIL	1	2012639
20	AUXILIARY SHEAVE ASSEMBLY	1	2006102	50	PLUG	2	64A7
∅	SET SCREW, Sheave	2	76F30	51	SCREW, Lube Tank to Skid	4	655EE040
				52	WASHER	4	95A5
	(Pump to Liner Group)			53	PLUG	1	64A6
21	ADAPTOR-HOSE	1	29Q10	54	COVER-LUBE OIL TANK	1	200PZH249
22	HYDRAULIC HOSE ASSEMBLY	1	2009247	55	NUT-WING	2	50H1
23	ADAPTOR-HOSE	1	29Q27	56	PLUG	1	64A9
24	REDUCER-PIPE	1	64N3	∅	NIPPLE	1	63L1
25	VALVE	1	90A25	∅	ELBOW	1	64V9
26	ELBOW-PIPE	1	64C5				

∅ Not Shown on Drawing.

* For Piston Lubricating Pump and Components Parts See Page 11.

Order by Part Number and Description. Reference Numbers are for your convenience only.

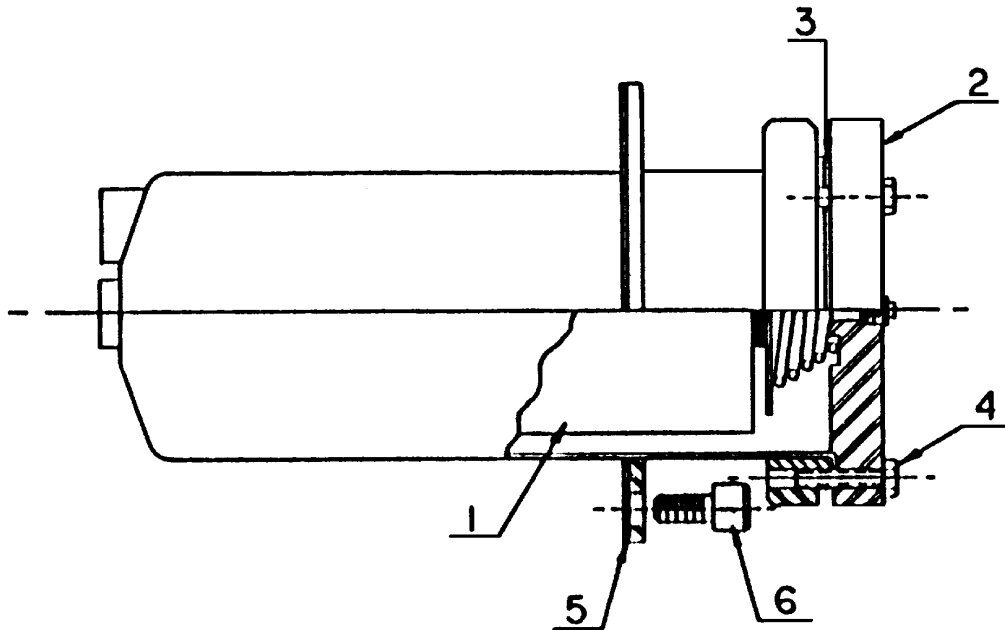

B76839

OIL FILTER

Ref. No.	Name of Part	Qty.	Part No.
	OIL FILTER ASSEMBLY, Includes Reference Numbers 1 thru 4	1	26C18
1	ELEMENT ASSEMBLY, Includes Reference Number 3	1	5E30
2	COVER	1	2109770
3	GASKET	1	2109771
4	SCREW	4	75A54
5	GASKET, Filter to Frame	1	25C1788N
6	SCREW-SoHd CAP, Filter to Frame	6	75P95

Order by Part Number and Description. Reference Numbers are for your convenience only.

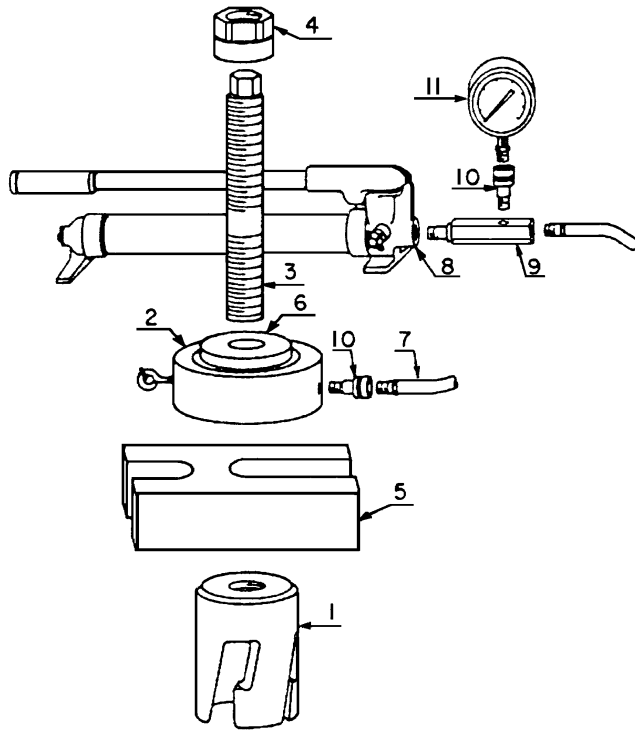

**VALVE SEAT PULLER – CENTER GUIDED TYPE
(OPTIONAL EQUIPMENT)**

Ref. No.	Name of Part	Qty.	Part No.
1	HEAD (Not Included with 10012 Puller)	1	100E13
	VALVE SEAT PULLER ASSEMBLY, Includes Reference No. 2 thru 11 .	1	100E12
2	HYDRAULIC JACK	1	2116728
3	CENTER STEM	1	2117314
4	CENTER STEM NUT	1	2117315
5	PULLER H BAR BASE	1	2116727
6	CENTER BUSHING #5	1	2117316
	CENTER BUSHING #6	1	2117517
7	HYDRAULIC HOSE	1	2117318
8	HYDRAULIC PUMP	1	2117319
9	GAUGE ADAPTOR	1	2117320
10	GAUGE COUPLER	2	2117322
	GAUGE COUPLER	2	2117321
11	GAUGE 170 TON	1	2117323
*	CARRYING CASE	1	2117055

* Not Shown on Drawing.

OPTIONAL EQUIPMENT

Ref. No.	Name of Part	Qty.	Part No.
	BAR, Valve Cover Tightening	1	62L62
	PIN, Valve Cover Tightening Bar	1	2009526
	HYDRILL DAMPENER (K10-5000)	1	200PZL622
	HOSE, For Charging Hydrill Dampener	1	200PZL127
	TOOL, Piston Rod Nut Removal	1	200PZL074
	PRESSURE GAUGE GROUP, Includes next 3 items	1	PZL75283
	GAUGE (0 – 6000 PSI)	1	27P70
	NIPPLE	1	63V32X60
	ELBOW	1	64EB241
	RELIEF VALVE GROUP, Includes next 4 items	1	PZL75284
	RELIEF VALVE (1000 PSI – 5000 PSI)	1	201559
	NIPPLE	1	63V48X60
	ELBOW	1	64EB242
	ELBOW	1	64D14
	BLOCK SUPPORT & DISCHARGE CROSS GROUP, Includes		
	301PZG4067 and PZJ74823 Groups	1	PZJ75285
	BLOCK GROUP (Includes next six items)	1	301PZG4067
	GASKET	2	25V24
	GASKET	2	25V17
	FLANGE	1	191161
	FLANGE	1	64EB240
	FLANGE	1	64EB50
	BLOCK GROUP (Includes next five items)	1	300PZG4067
	BLOCK	1	205PZL231
	STUD	24	206PZL110
	NUT	24	50AW11
	STUD	16	208PZL110
	NUT	16	50AW13
	SUPPORT GROUP (Includes next three items)	2	PZJ74823
	BASE	1	195100
	BASE	2	5015475
	SUPPORT (Includes next five items)	2	201845T2
	SCREW	2	201853
	NUT	2	50W12
	PIN	2	62R98
	NIPPLE	1	201846
	SCREW	1	655EJ200

GARDNER DENVER UNIT RECORD

The following unit identification plate is provided as a convenience to you, our valued Gardner Denver customer. Please take the time to copy all the information from the actual nameplate of your unit. The model number, date manufactured and serial number will be required when contacting the company or your distributor for information or replacement parts.

DANGER-READ INSTRUCTION MANUAL BEFORE MOVING OR OPERATING UNIT						
MODEL	<input style="width: 90%;" type="text"/>	DATE MFG	<input style="width: 90%;" type="text"/>	SERIAL NO.	<input style="width: 95%;" type="text"/>	
ID NO.	<input style="width: 90%;" type="text"/>	MAX TEMP	<input style="width: 90%;" type="text"/>	C/CASE OIL CAP. GAL	<input style="width: 95%;" type="text"/>	
SERVICE	RATED MAX INPUT BHP	RATED MAX INPUT RPM	RATED MAX PUMP RPM	DISCHARGE MAX PSI W.P. OF FLUID CYL.	SUCTION MAX PSI W.P. OF FLUID CYL.	MAX INPUT RPM AT MAX PRESSURE
CONTINUOUS	<input style="width: 90%;" type="text"/>	<input style="width: 90%;" type="text"/>	<input style="width: 90%;" type="text"/>	<input style="width: 90%;" type="text"/>	<input style="width: 90%;" type="text"/>	<input style="width: 90%;" type="text"/>
INTERMITTENT	<input style="width: 90%;" type="text"/>	<input style="width: 90%;" type="text"/>	<input style="width: 90%;" type="text"/>	<input style="width: 90%;" type="text"/>	<input style="width: 90%;" type="text"/>	<input style="width: 90%;" type="text"/>
DISPLACEMENT & PRESSURE AT RATED RPM, SEE O-M MANUAL FOR ADDITIONAL SPECIFICATIONS						
SIZE	<input style="width: 90%;" type="text"/>	<input style="width: 90%;" type="text"/>	<input style="width: 90%;" type="text"/>	<input style="width: 90%;" type="text"/>	<input style="width: 90%;" type="text"/>	<input style="width: 90%;" type="text"/>
GPM	<input style="width: 90%;" type="text"/>	<input style="width: 90%;" type="text"/>	<input style="width: 90%;" type="text"/>	<input style="width: 90%;" type="text"/>	<input style="width: 90%;" type="text"/>	<input style="width: 90%;" type="text"/>
PSI	<input style="width: 90%;" type="text"/>	<input style="width: 90%;" type="text"/>	<input style="width: 90%;" type="text"/>	<input style="width: 90%;" type="text"/>	<input style="width: 90%;" type="text"/>	<input style="width: 90%;" type="text"/>
INTERMITTENT DUTY MAXIMUM PRESSURE, SEE O-M MANUAL FOR ADDITIONAL SPECIFICATIONS						
PSI	<input style="width: 90%;" type="text"/>	<input style="width: 90%;" type="text"/>	<input style="width: 90%;" type="text"/>	<input style="width: 90%;" type="text"/>	<input style="width: 90%;" type="text"/>	<input style="width: 90%;" type="text"/>
Gardner Denver				PURCHASER ID NO.		<input style="width: 95%;" type="text"/>
2000PA496	Gardner Denver Machinery Inc. Quincy, Illinois			MADE IN USA		
GIVE MODEL, ID NO. AND SERIAL NO. WHEN ORDERING REPAIR PARTS OR SERVICE						

**2000PA496
(Ref. Drawing)**

Gardner

Denver

For additional information contact your local representative or Gardner Denver Machinery Inc., Customer Service Department, 1800 Gardner Expressway, Quincy, Illinois 62301
Telephone: (800) 682-9868 FAX: (217) 224-7814



Sales and Service in all major cities.

For parts information, contact Gardner Denver, Master Distribution Center, Memphis, TN
Telephone: (800) 245-4946 FAX: (901) 542-6159

Specifications subject to change without notice.
Copyright 1998 Gardner Denver Machinery Inc.

Litho in U.S.A.